



Lubricant Consult GmbH

Food, Beverage & Pharma Industry



LUBCON Business Fields



Smart Task Control



High Performance
Certified H1 Lubricants



Special Bearings



Lubrication System

Food Grade Certification



2Probitity



More than 170 high performance certified H1 lubricants

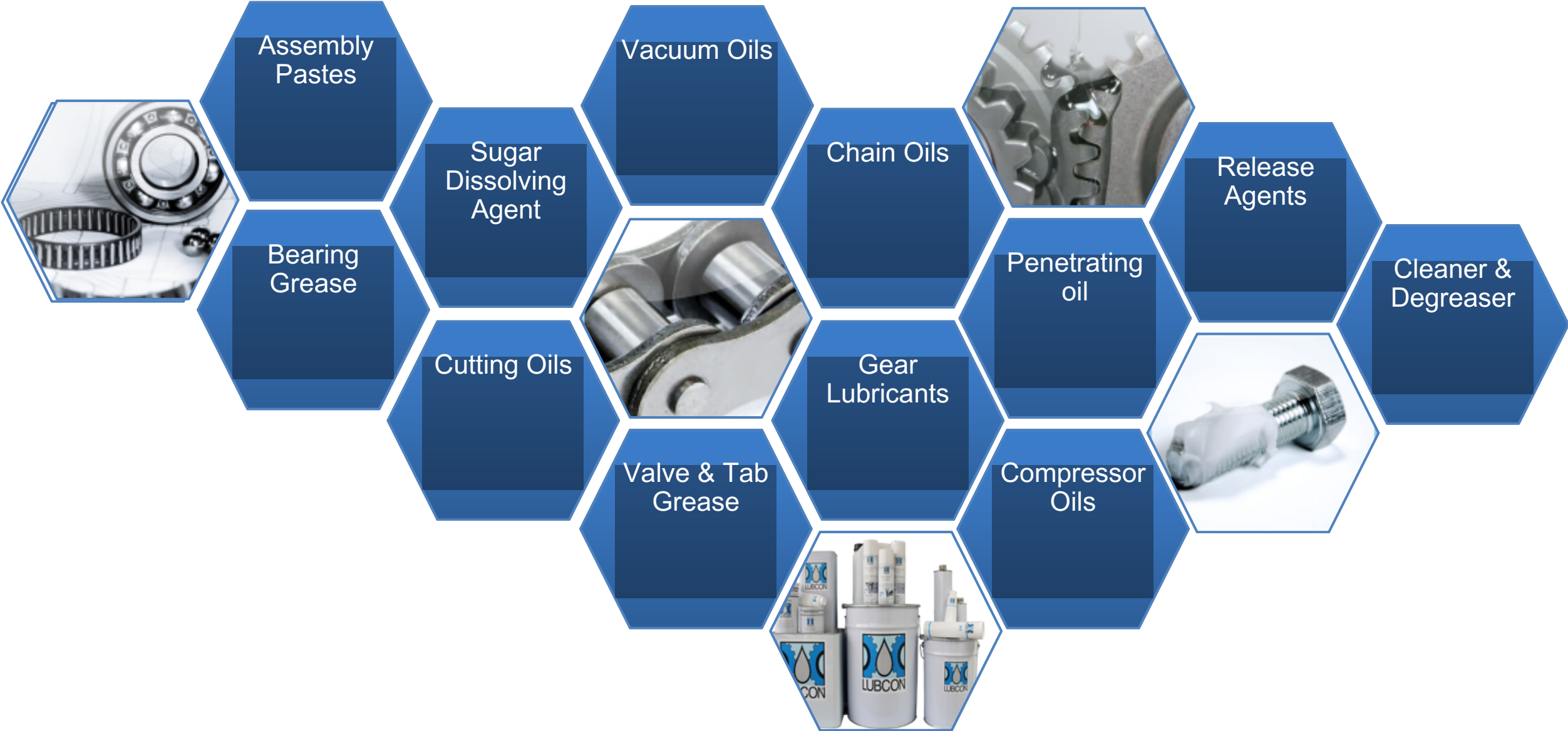

Roller, Plain & Linear Bearing



Multipurpose Grease

Turmosynthgrease A

- Light multipurpose white oil / aluminum grease
- Good water resistance, corrosion protection & lubricating properties.

Turmosynthgrease AL

- Highly refined white oil / al-complex soap grease
- Applications from low to medium temperatures & speeds
- Resistance to hot & cold water, outstanding adhesive properties

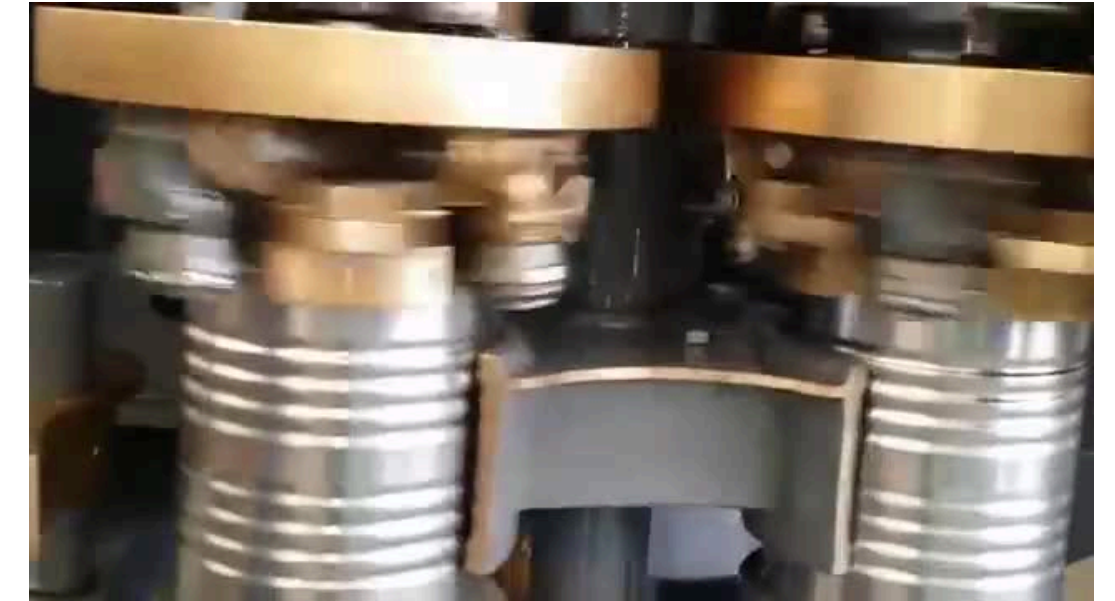

Can seamer



Conveyor

High Performance Synthetic Grease

Turmosynthgrease FG

- Mixture of synthetic oils / aluminum-complex soap
- Hot & cold water resistance, corrosion & wear protection
- Very good adhesive property, high load carrying capacity & high oxidation resistance

Turmosynthgrease LM

- Fully synthetic oil / aluminum-complex soap
- Hot & cold water resistance, corrosion & wear protection
- High load carrying capacity & high oxidation resistance
- Long grease service life

High Performance Synthetic Grease

Turmosynthgrease ALN

- Fully synthetic high performance grease
- Long life - polyurea-aluminium special soap
- Grease for high speed, high load & high temperature applications

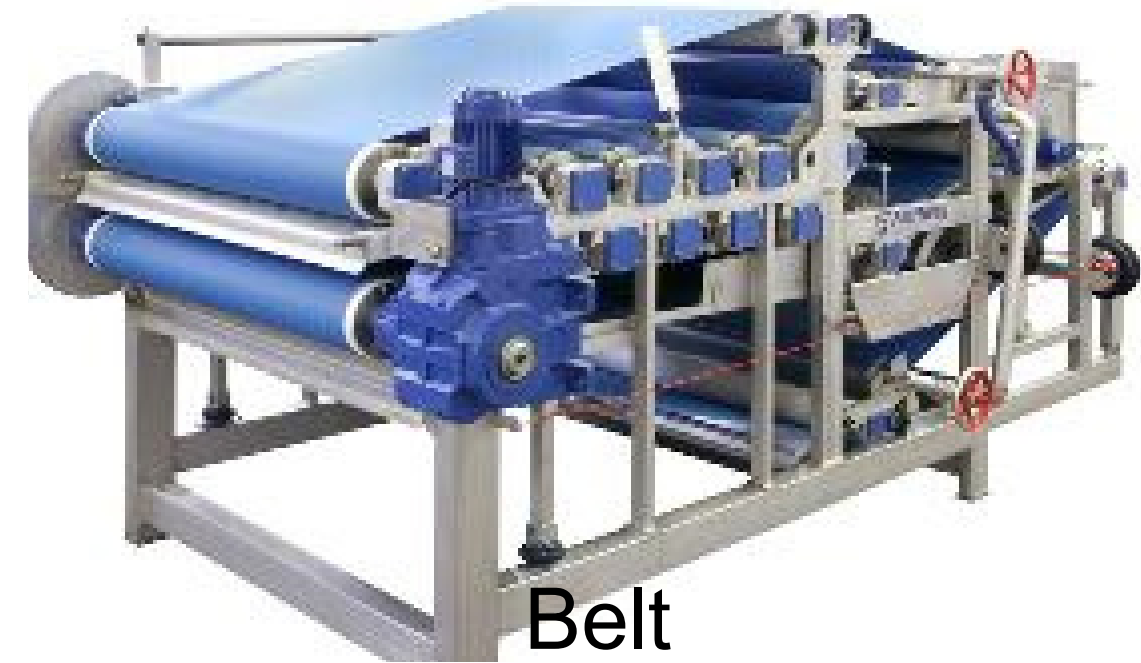

Belt
Press



Motor

Water Resistance EP Grease

Turmosynthgrease CSX

- Fully synthetic calcium sulphonate complex grease
- Excellent mechanical stability & optimum performance under extreme conditions
- Outstanding water resistance, excellent anti-corrosion & anti-wear properties



Bearing



High Performance Low Temperature Grease

Turmosynthgrease LT

- Fully synthetic high performance grease
- Long life - polyurea-aluminium special soap
- Suitable down to -54°C

Spiral / Tunnel freezer



High Performance High Temperature Grease

Turmotemp II/400 FG

- Economical PFPE/PTFE grease
- Suitable up to +260°C

Turmotemp II/400 CL 2

- PFPE/PTFE high temperature grease
- Suitable up to +260°C

Sintono Mega 2

- PFPE/Polyurea high temperature grease
- PTFE free
- Suitable up to +260°C



Wafer oven



Decanter

Antimicrobial High Performance Synthetic Grease

Turmosynthgrease ALN 1002 clean

- Synthetic grease with antimicrobial additives
- Prevents growth of pathogenic germs in the grease
- Eliminates risk of microbial contamination in case of accidental contact



Turmsilon LMI 5000 clean

- Silicone grease with antimicrobial additives
- Suitable for lubrication of seals and rubber joints

Gearbox & Open Gear



Multipurpose Gear Oil

Turmosynth VG

- Multipurpose white oil suitable for wide range of gearboxes & hydraulic systems
- Semi synthetic with highly effective additive package



Pineapple peeler (Ginaca)



homogenizer

High Performance Synthetic Gear Oil

Turmosynthoil GV

- Fully synthetic gear oil
- Wide temperature range and long service life

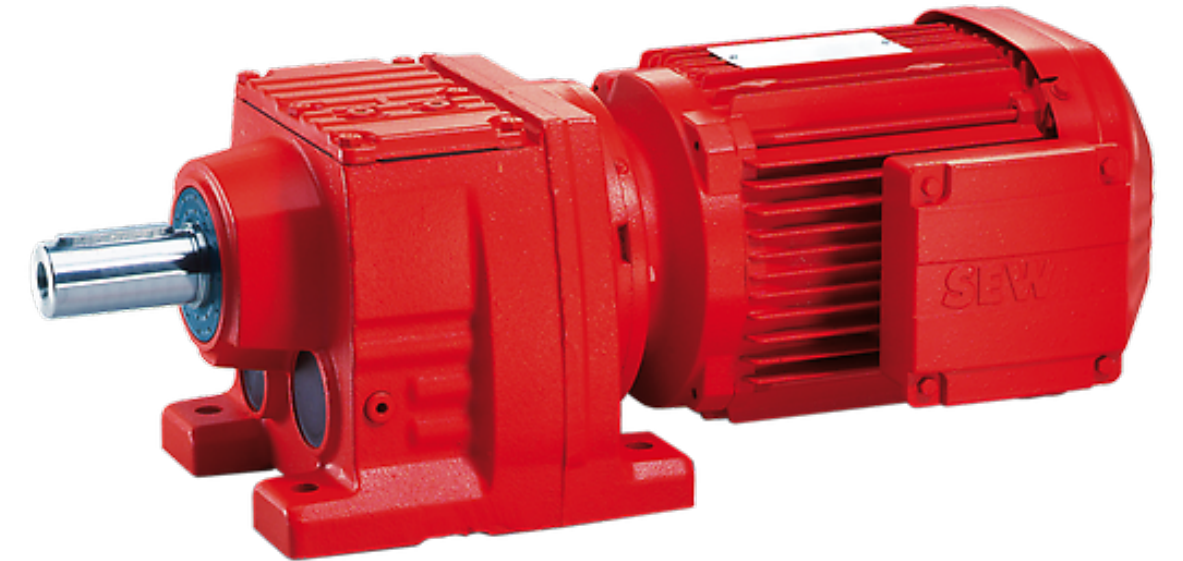

Turmoflush FG 15

- Low viscosity white oil suitable for cleaning and flushing of old oil in gearboxes and mechanical system
- When converting from non H1 to H1 oil



High Performance Synthetic EP Gear Oil

Turmosynthoil PG

- Reduced friction and energy consumption in worm & bevel gears or geared motors
- High load carrying capacity and long service intervals
- FZG Scuffing load stage $A/8,3/90 >12$

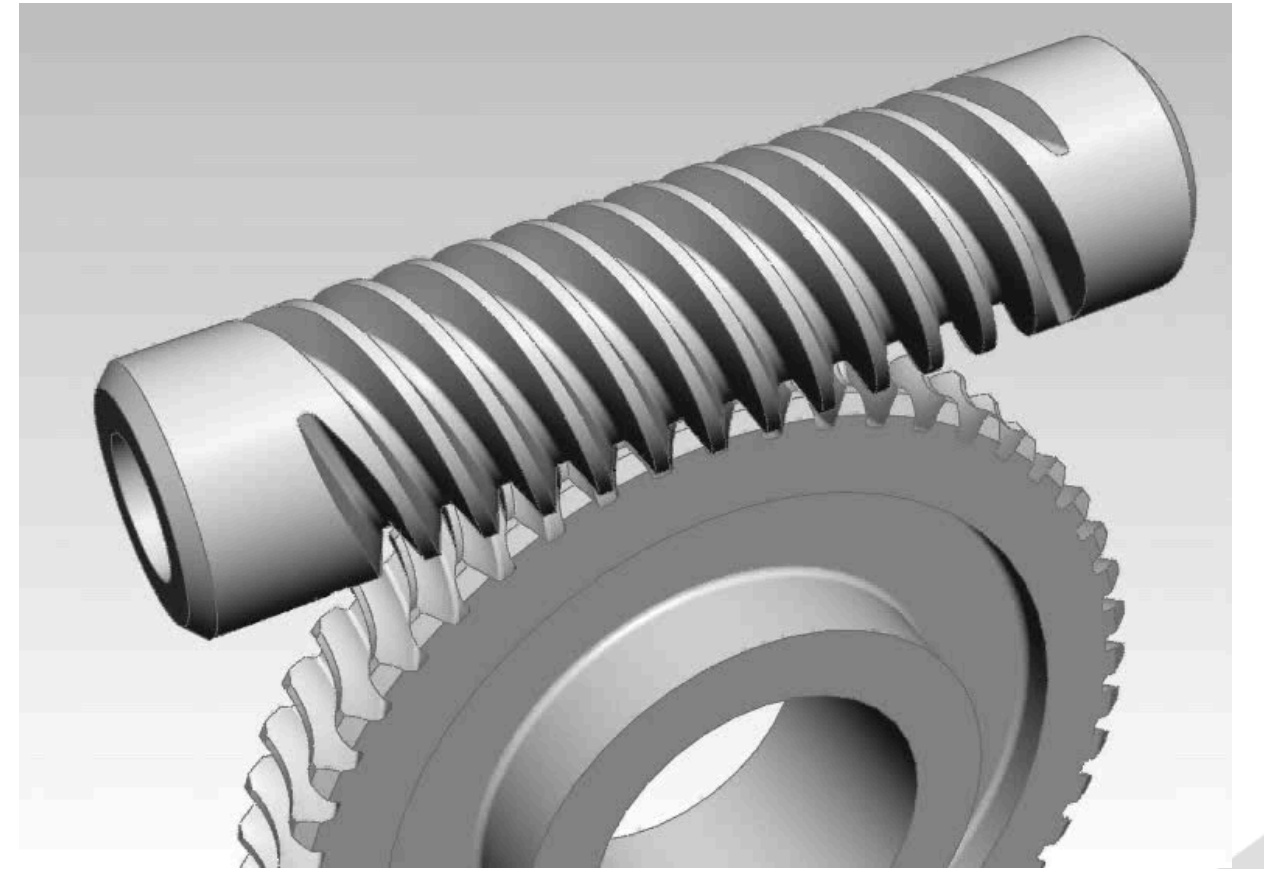

Semifluid Gear Grease

Turmosynthgrease AL 2502/000

- NLGI 00 or 000 consistency
- Alternative to gear oil in risky applications

Turmosynthgrease ALN 2502/000

- Fully synthetic semifluid grease
- Wide temperature range and long service life
- NLGI 00 or 000 consistency
- Reduces risk of potential product contamination



Open Gear

Turmosynth VG 4800 (aerosol)

- Highly adhesive oil with high load carrying capacity
- Excellent suitability for the lubrication of open gear

Turmosynthgrease ALN 8001 (grease)

- Synthetic high performance polyurea grease with outstanding adhesive properties and high base oil viscosity providing high load carrying capacity



Chain & Conveyor



Multipurpose Chain Oil

Turmofluid LMI 300 (aerosol)

- Silicon free synthetic multipurpose oil
- Excellent penetrating properties
- Leaves dry lube film for reduced dust attraction
- Also suitable as release agent



Water Resistance Chain Oil

Turmosynthoil 75 TF(aerosol)

- Very adhesive synthetic oil
- With PTFE additives for additional wear protection
- Excellent water and corrosion resistance
- Good separating properties also in molds



Low Temperature Chain Oil

Turmosynthoil GV 32

- Developed for chain in a spiral freezers
- Penetrates into the structure of the chain and protects it at extreme low temperature



Spiral freezer



Extreme Pressure Chain Oil

Turmosynth VG 4800 (aerosol)

- Transparent highly adhesive oil with high load carrying capacity
- Also suitable for the lubrication of open gear

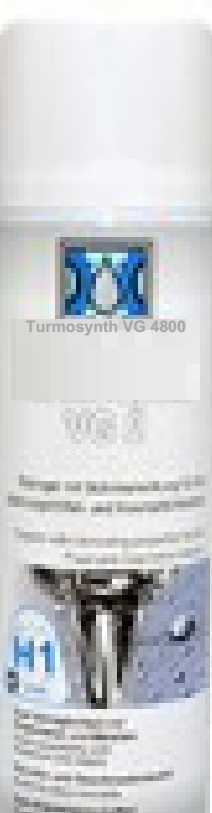
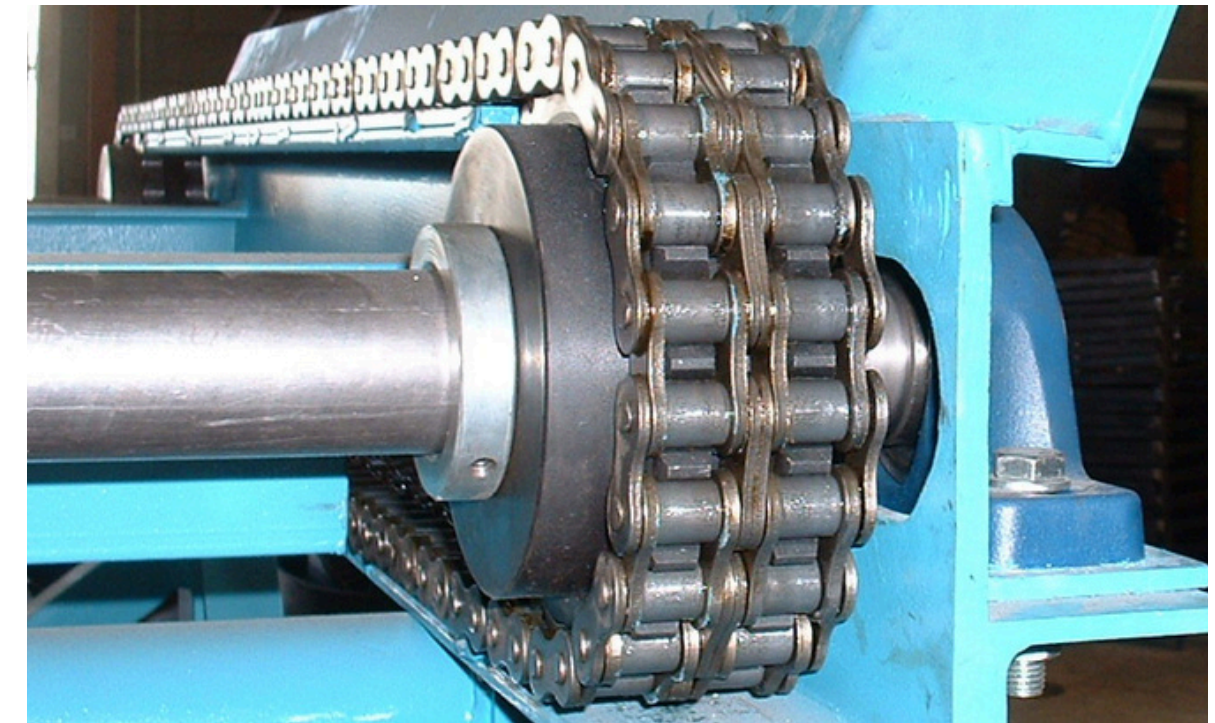

High Temperature Chain Oil

Turmosynthoil HTC

- Suitable up to 250°C
- Solid free advanced synthetic ester oil
- Low evaporation loss



Pin chain



Baking oven

Chain Oil for Aceptic Process

Turmosynthoil GV clean

- Chain oil with antimicrobial additives to prevent growth of pathogenic germs, mould & fungus in the oil



Tetra Pak



Pharmaceutical



Releasing & Sliding Surface

Sliding Surface & Conveyor Chain Oil

Turmosynth VG 46 TF

- Dry lubricant with adhesive properties
- Specially developed for the lubrication of flat top chain conveyor for the beverage industry
- Very good alternative to soap solution
- Improves personnel safety by reducing slip hazard
- Provides enhanced line efficiency

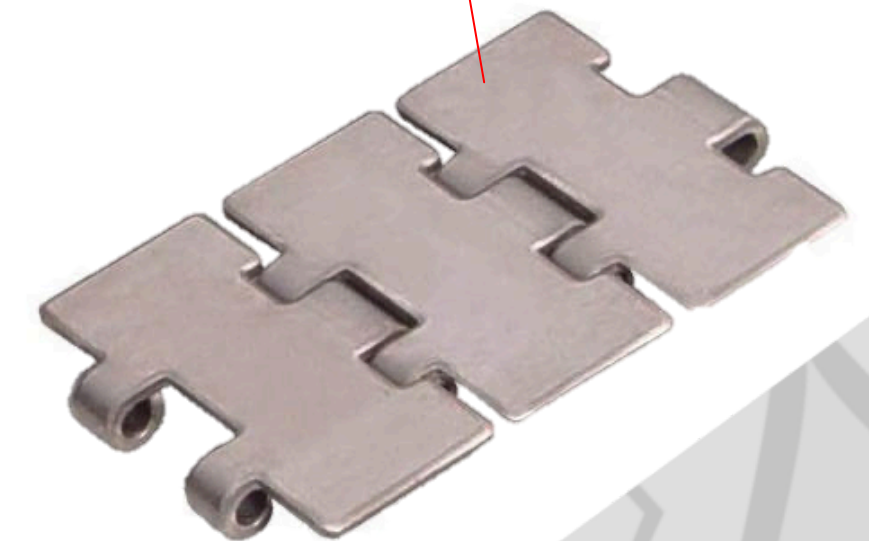

Release & Sliding Agent

Turmsilon® M 100(aerosol)

- Silicon based release and sliding agents
- Neutral in colour, odour and taste



Sliding conveyor

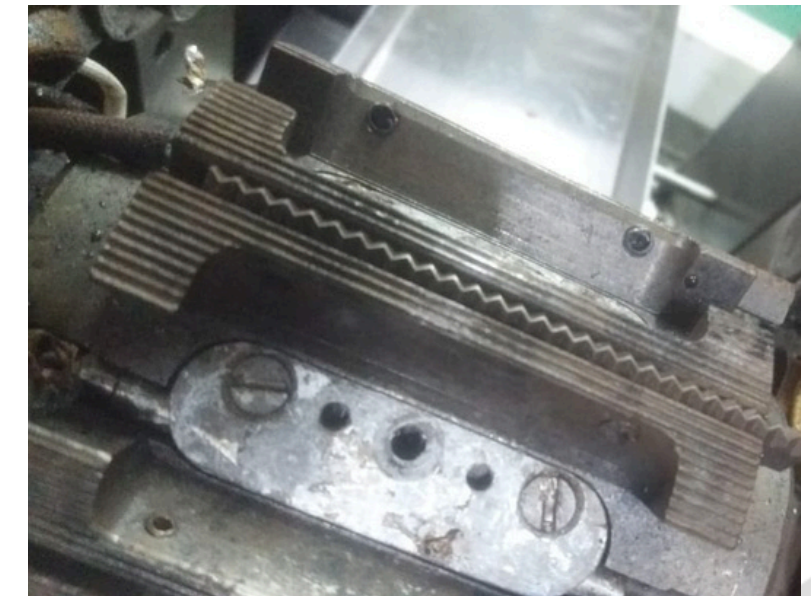

Packaging machine sealer

Paper Cup

Turmsynth VG 68 PC

- Odorless
- Tasteless
- Stain free
- Toxic free





McDonald standard test

eurofins | Eurofins Consumer Product Testing GmbH
Am Neuländer Gewerbepark 4
D-21079 Hamburg
GERMANY

Tel: +49 40 49294 6900
Fax: +49 40 49294 6800

Product/Testing-HQ@eurofins.com
www.product-testing.eurofins.com

Eurofins CPT GmbH / Am Neuländer Gewerbepark 4 - D-21079 Hamburg
JPG Lubricants Asia Pacific Corp.
Attn: Jun Santos
Variata Bldg, Unit 2 Bk. 14 Lot 4 Slicas Village
Brgy. San Francisco
4024 Laguna
PHILIPPINES

Person in charge Mrs A. Fuchs - 6843
Client support Mrs A. Fuchs - 6843

Report date 24.01.2020
Page 1/2

Analytical report AR-20-JR-001759-01

Sample Code 799-2020-00191206

Reference	Paper Cups
Client sample code	N/A
Purchase order code	N/A
Lot-no.	N/A
Number of received Samples	30
Ordered by	Jun Santos
Submitted by	Jun Santos
Carrier	DHL
Reception date	13.01.2020
Start/end of analyses	17.01.2020 / 24.01.2020

TEST RESULTS

Physical-chemical Analysis

JR11F Migration of MOSH/MOAH in 95% Ethanol (#)		
Method: Internal, PV 01482 2018-04, LC-GC-FID		
Migration Type	Filing	Hours
Duration for first migration	2	
Temperature for first migration	70	°C
Sum MOSH/POSH C20-C35 (saturated) calculated	9.3	mg/kg food
Sum MOAH C16-C35 (aromatic) calculated	<0.1	mg/kg food
Surface volume ratio	1.2/250	dm ² /ml
Layer thickness	not applicable	
Variation from Norm	No	

* = below indicated quantification level
(#) = Eurofins Consumer Product Testing (Hamburg) is accredited for this test.

JUDGEMENT

A complex mixture of linear and branched hydrocarbons (MOSH) as well as aromatic hydrocarbons (MOAH), together commonly referred to as 'mineral oils', have not been detected in a food-simulant (migration). Currently, no legal limits exist for these substances. According to the latest draft of the German Mineral Oil Ordinance the migration out of food contact materials made from recycled fibers should not exceed a limit of 0.5 mg/kg food simulant for MOAH (C16-35). A limit for the MOSH-fraction is currently not planned.

- MOAH - analytically confirmed

The results of examination are evaluated in the attached certificate.
Detailed information is available in the test certificate or under:
Eurofins CPT GmbH / Am Neuländer Gewerbepark 4 - D-21079 Hamburg
Phone: +49 40 49294 6900 / Fax: +49 40 49294 6800
E-mail: product-testing@eurofins.com
Our Service Terms & Conditions of Customers (CSC) are available under:
Customer Service: +49 40 49294 6900
Web: www.eurofins.com
Our Service Terms & Conditions of Customers (CSC) are available under:
Customer Service: +49 40 49294 6900
Web: www.eurofins.com

Mineral oil limit

intertek
Total Quality Assured.

TEST REPORT

APPLICANT: JPG Lubricants Asia Pacific Corp.
Saudades Bldg, Blk 1, Lot 50 & 51
Jubilacion New Biñan Strip
Brgy. Zapote
Biñan, Laguna, 4024
PHILIPPINES

REPORT NUMBER: WOHK13496-A
DATE: October 18, 2019

Attn: Jun Santos

SAMPLE DESCRIPTION: One (1) group of submitted sample said to be Paper Cups for McDonald's.

Sample received date: October 14, 2019
Date of testing started: October 14, 2019
Date of testing ended: October 16, 2019

TEST CONDUCTED: AS REQUESTED BY THE APPLICANT, FOR DETAILS REFER TO ATTACHED PAGE(S)

CONCLUSION:

Tested Samples	Standard	Result
Tested components of submitted samples	McDonald's Specification TS 422 Rev. 1 - Toxic elements analysis	Pass
	U.S. CFR Title 16 (CPSA Regulations) Part 1303 - Total lead content	Pass
	U.S.21 CFR F.D.A. Regulation Part 176.170 on paper & paperboard	Pass

PAGE 1/TO BE CONTINUED TOTAL 3 PAGES

Authorized By:
Intertek Testing Services
Shenzhen Ltd.

Nelson Chan

Nelson Chan, PhD
Vice President - Asia Pacific Operations
Risk Assessment & Management

Intertek Testing Services Shenzhen Ltd.
West Side of LP and S.A.S.P. of Bldg. 1, S.A.S.P. of Bldg. 5,
Yuanzhong Science and Technology Industrial Park,
No. 4012, Wuhai Ave. North, Bantian Street,
Longgang District, Shenzhen, P.R. China, Postcode 518122
深圳市宝安区西乡街道铁岗社区铁岗大道4012号
深圳市宝安区西乡街道铁岗社区铁岗大道4012号
铁岗1号综合楼1-5层 邮编 518122

China Toll-Free: 400 886 9926
Attention is drawn to the terms and conditions printed overleaf!

Toxic element limit

Compressor & Vacuum Oil

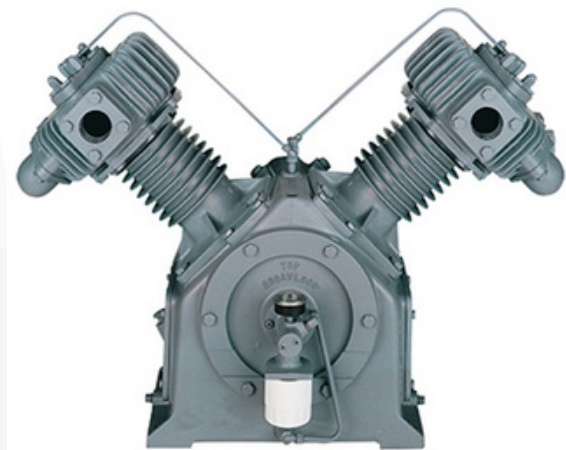
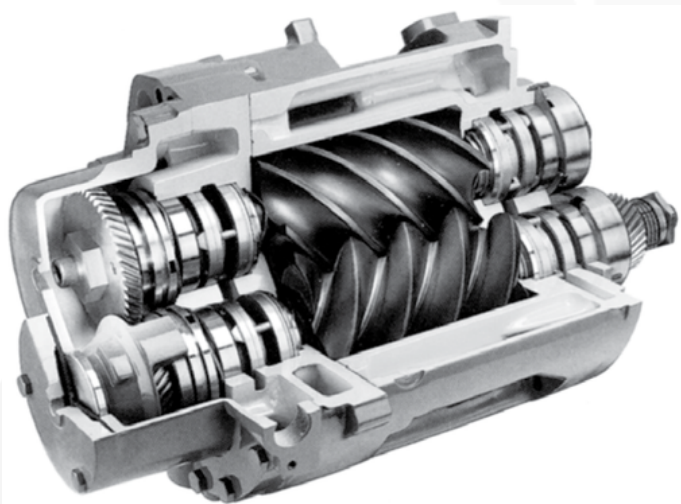

Compressor Oil

Compguard FG

PAO / 4000 hrs

Compguard FGX

PAO / Polyglycol / 8000 hrs

Compclean STS

Cleaning agent

Turmosynth HPX

Ester / 2000 hrs



Screw type

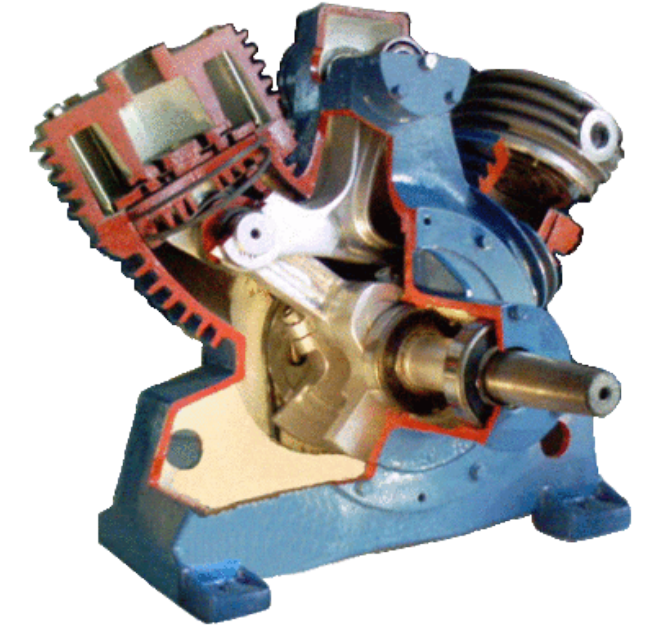

Piston type

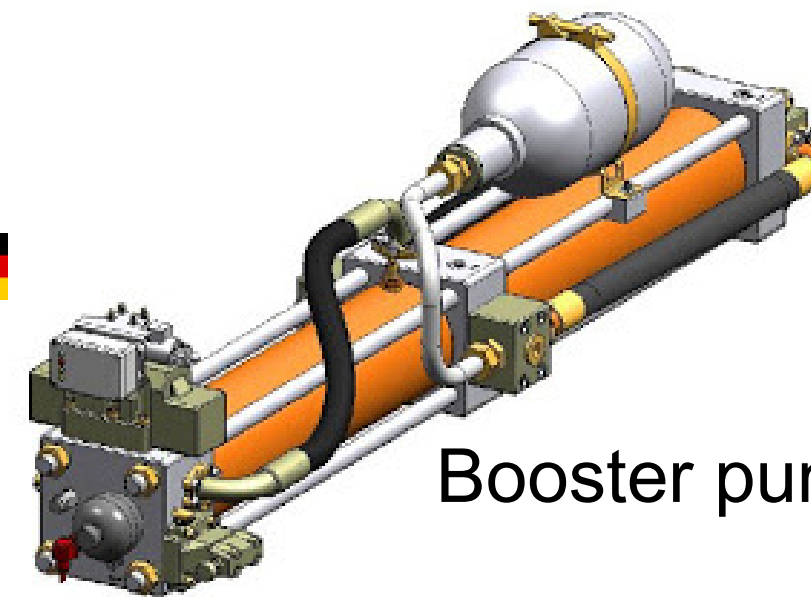

Booster pump

Pneumatic Oil

Turmosynthoil GV 32 (clean)

- Synthetic oil with antimicrobial additives
- Prevents growth of pathogenic germs, especially mould fungus, in the oil
- Developed for oil mist lubrication in pneumatic systems



Oil reservoir

Vacuum Oil

Compguard VPO 100

- Synthetic vacuum pump oil for air and nitrogen rotary vane pumps
- For constant low vapor pressure





Hydraulic Oil

Hydraulic Oil

Turmosynthoil VG

- Multipurpose white oil suitable for wide range of hydraulic systems
- Semi synthetic with highly effective additive package

Turmosynthoil GV

- Fully synthetic hydraulic oil
- Wide temperature range and long service life

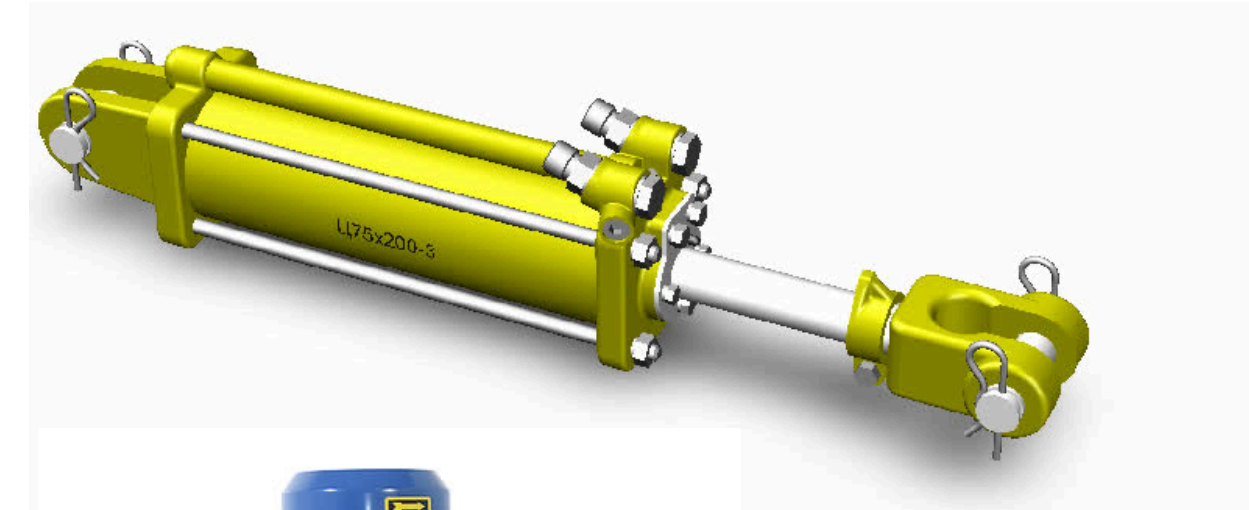

Hydraulic system

Seals, Valve & Fitting



Seals Grease

Turmsilon® LMI 5000

- Silicone grease for seal and rubber joint lubrication
- Resistant to hot and cold water & disinfectants



Seals Grease

Turmosynth 2000

- Semi-synthetic, very adhesive valve and fitting grease
- Stable towards hot and cold water

Turmosynthgrease LMI 2

- Special tab and valve grease
- Resistant to milk and fruit acids, neutral to beer foam





Maintenance

Cleaner & Degreaser

Turmosynth VG 1 (aerosol)

- Cleaner & Degreaser suitable to remove oil, grease and wax
- Quickly and completely evaporating

Turmosynth VG 2 (aerosol)

- Cleaner with lubricating properties
- Leaves durable lubricating film

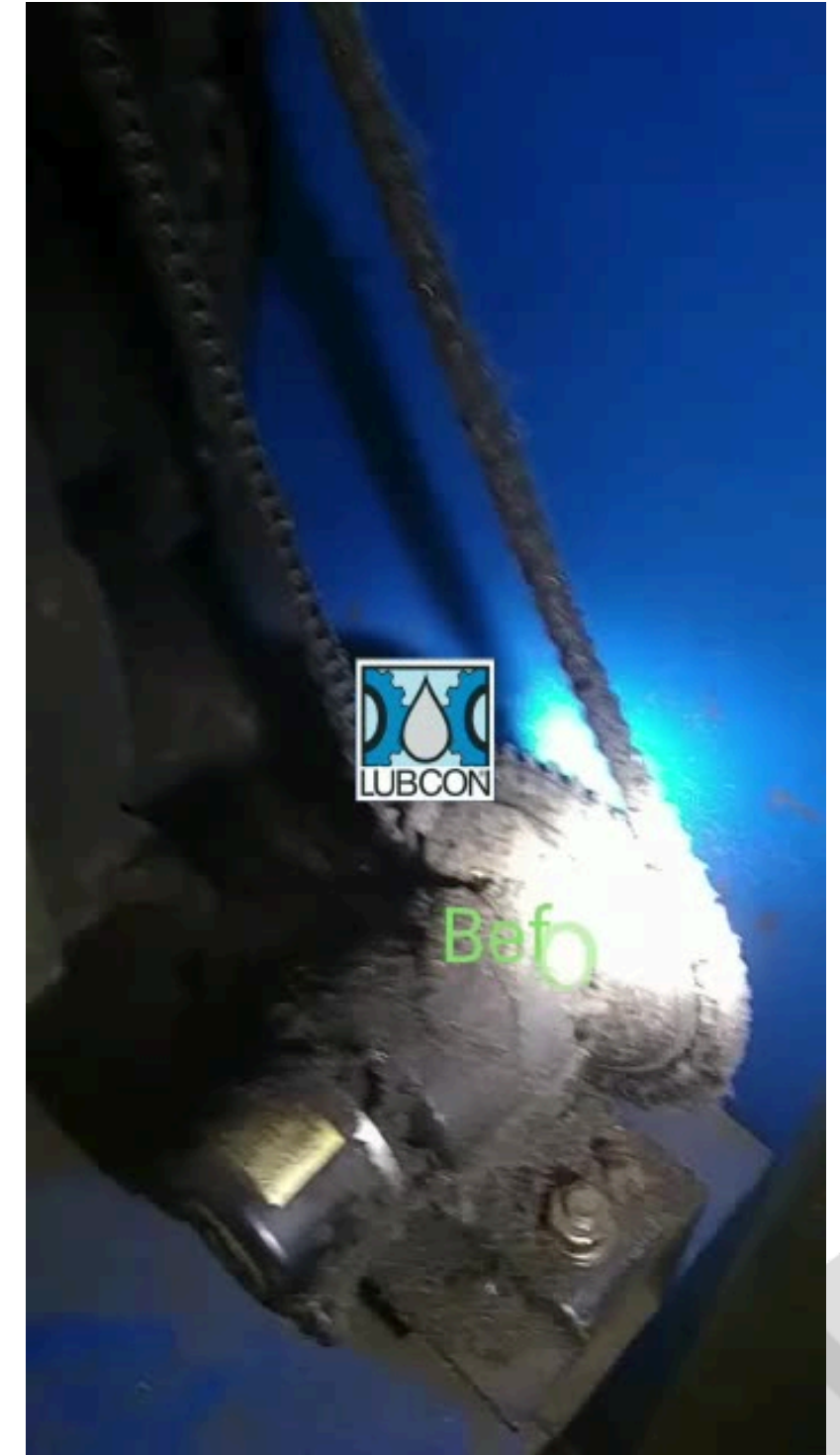

Sugar Dissolver

Elephants Milk

- Sugar dissolving lubricant
- Optimum water solubility

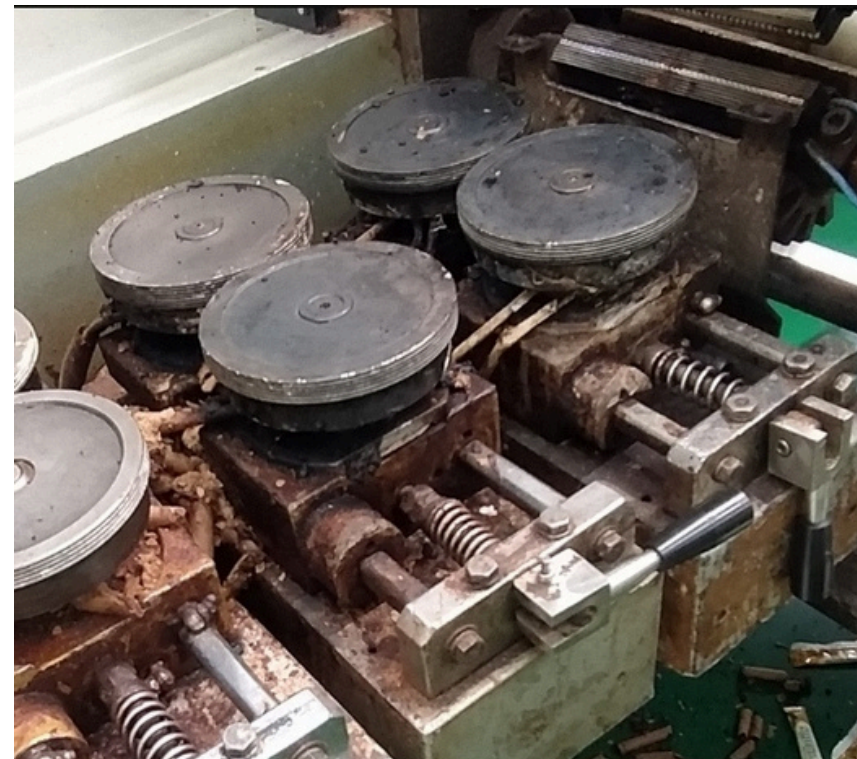

Synthetic Penetrating Oil

Rapid FG 15 (aerosol)

- Clean and loosen rusted parts
- Leaves durable lubricating film



Assembly & Anti Seize Paste

Turmosynth® TAS white

- Metal free assembly paste & sliding agent
- Good separating properties at high contact pressure
- Protection against fretting corrosion, good lubricity

Turmosynth® TAS LMI

- Metal free assembly paste & sliding agent
- Good separating properties at high contact pressure
- Protection against fretting corrosion, good lubricity



Maintenance Free Bearing



Lubrication Not Require

Wet & Dusty Environment

DMK TC 100

- Temperature: 100°C
- Speed factor: 120,000 ndm DGBB
50,000 ndm roller
bearing
- Coating: Manganese phosphate



Wet



Dusty

Motor Bearing

DMK HT 220

- Temperature: 220°C
- Lubricant: Ester / PFPE
- Speed factor: 1,200,000 ndm



Motor



Blower

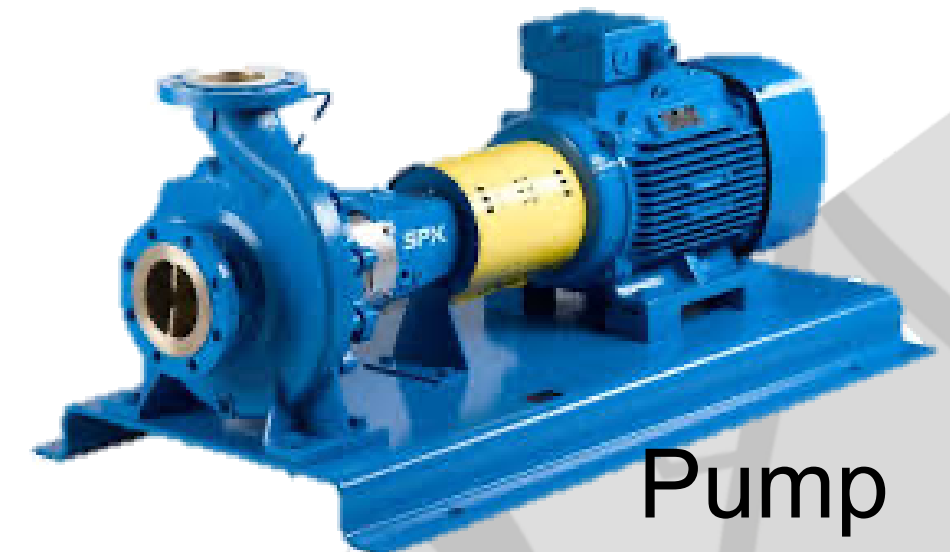

Pump

High Temperature Bearing

DMK HT 250

- Temperature: 250°C
- Lubricant: PTFE / PFPE
- Speed factor: 300,000 ndm

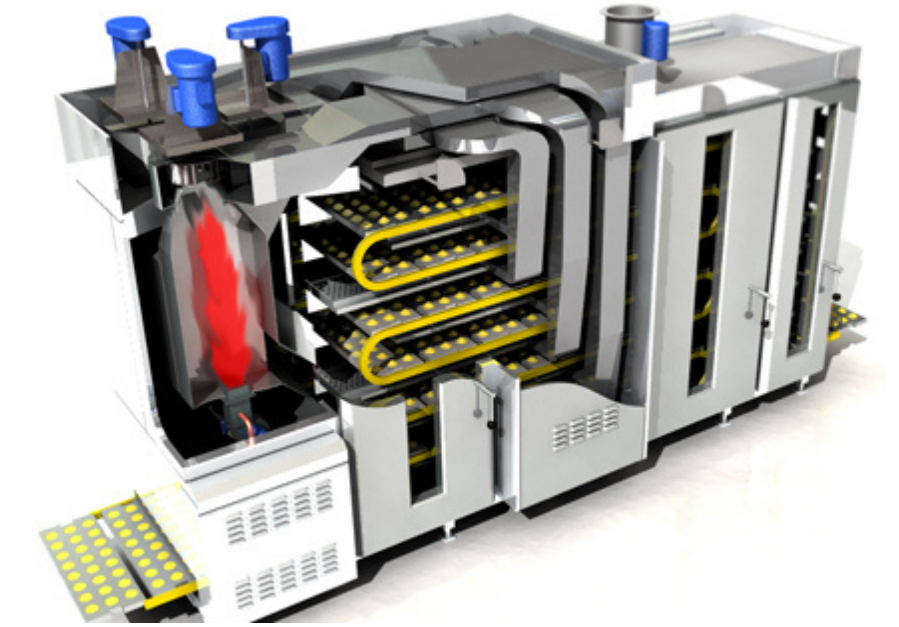
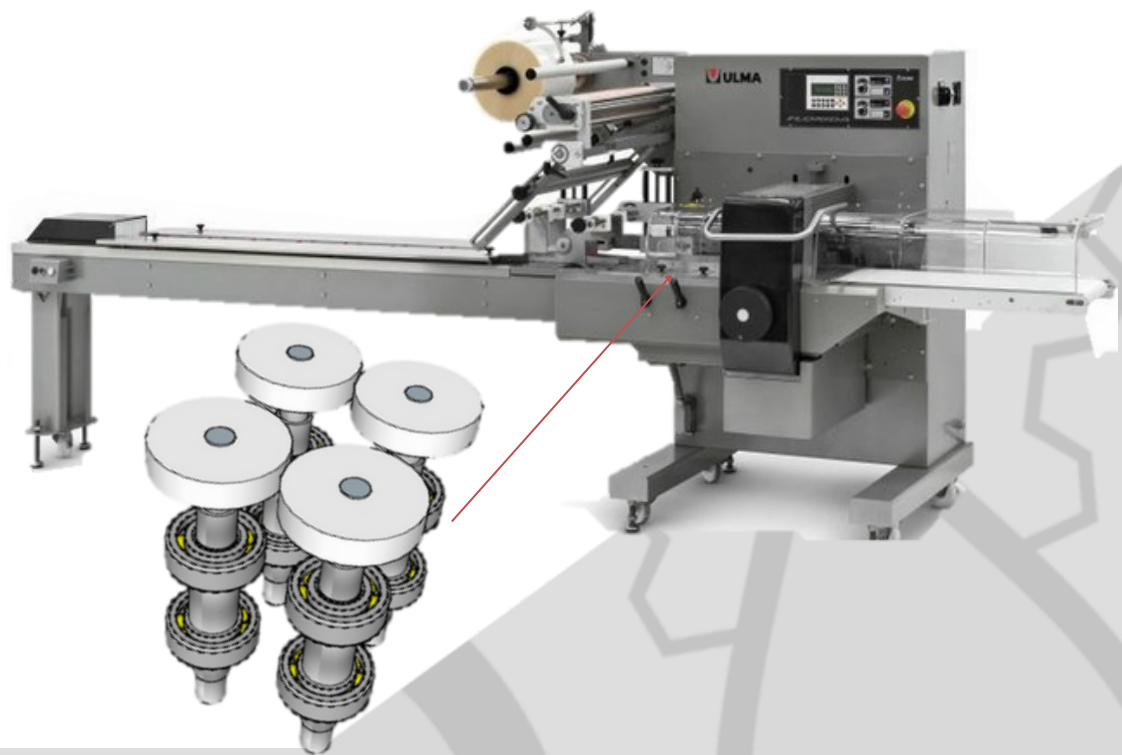

High Temperature Bearing

DMK HT 300

- Temperature: 300°C
- Lubricant: Turmopast SLC
- Speed: max 100 rpm
- Coating: Manganese phosphate



Coal fired boiler



Baking oven

Lubrication System



Lubrication System

Amount

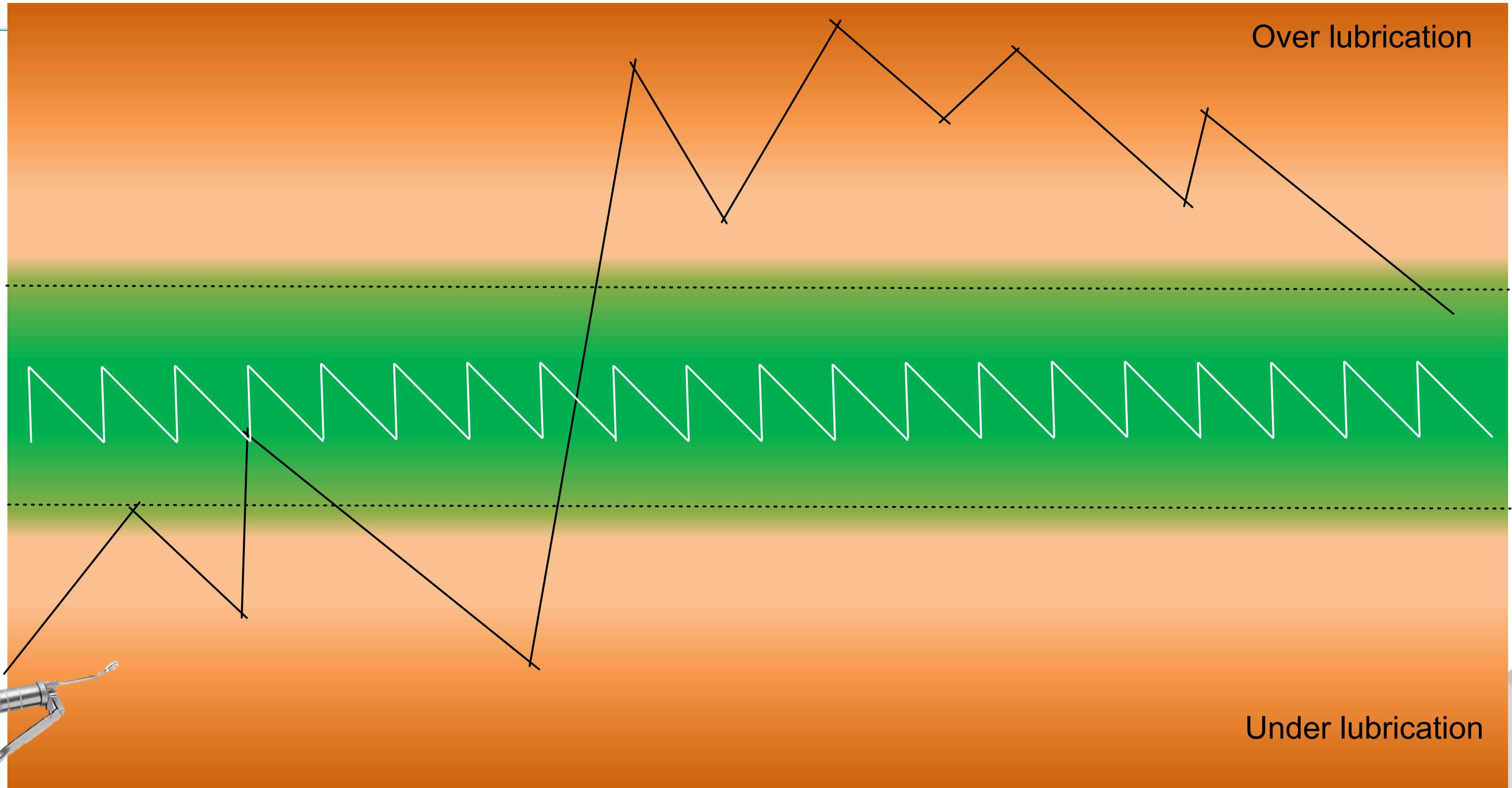
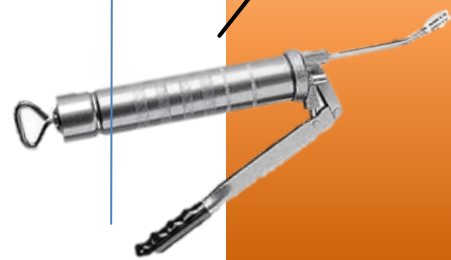

Over lubrication

Optimum

Under lubrication



Turmolube



Micromax 120



Duomax 160



Quattromax 30



Sixmax 160



Easymatic



TLB 2000

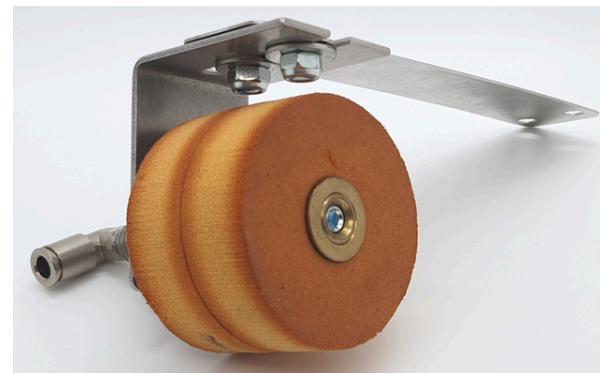

Chainlube System

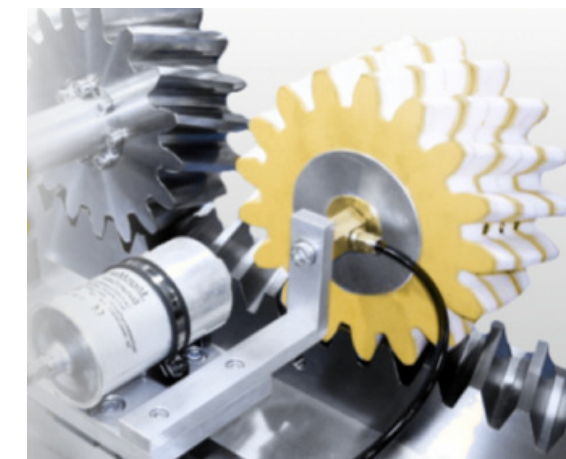

Gearlube System



SL 60



Lubrication Management



Smart Task Control

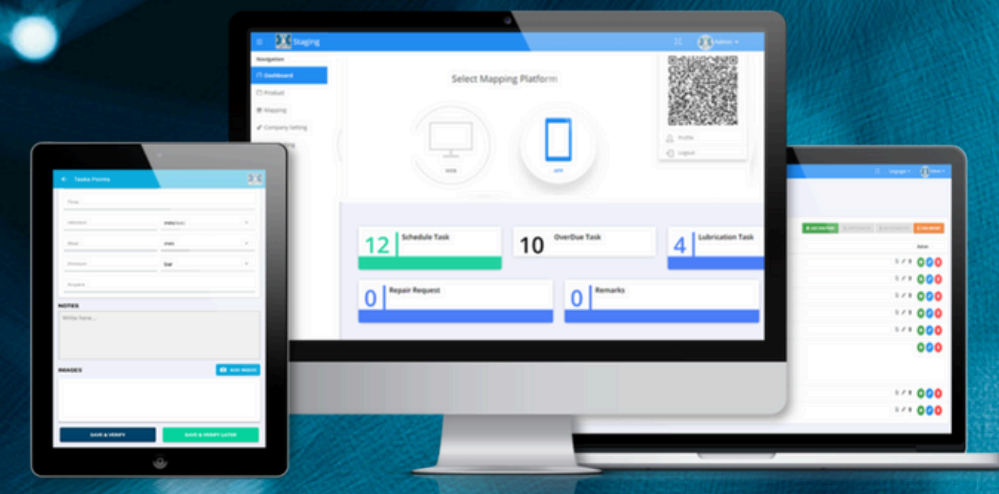

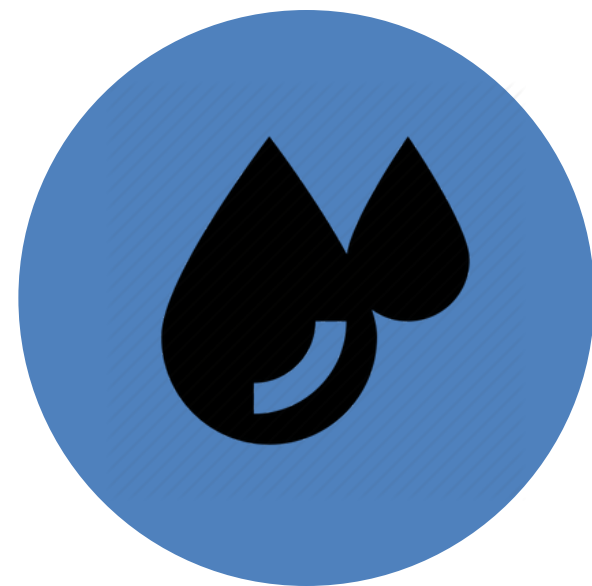

Right Product



Right Quantity

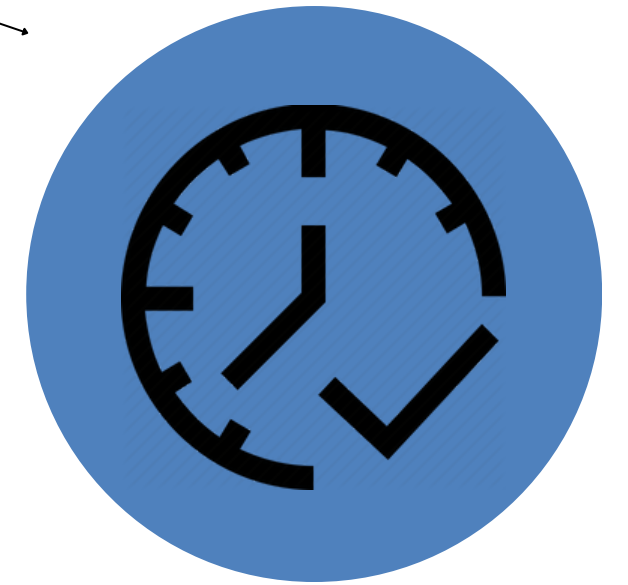

Right Time

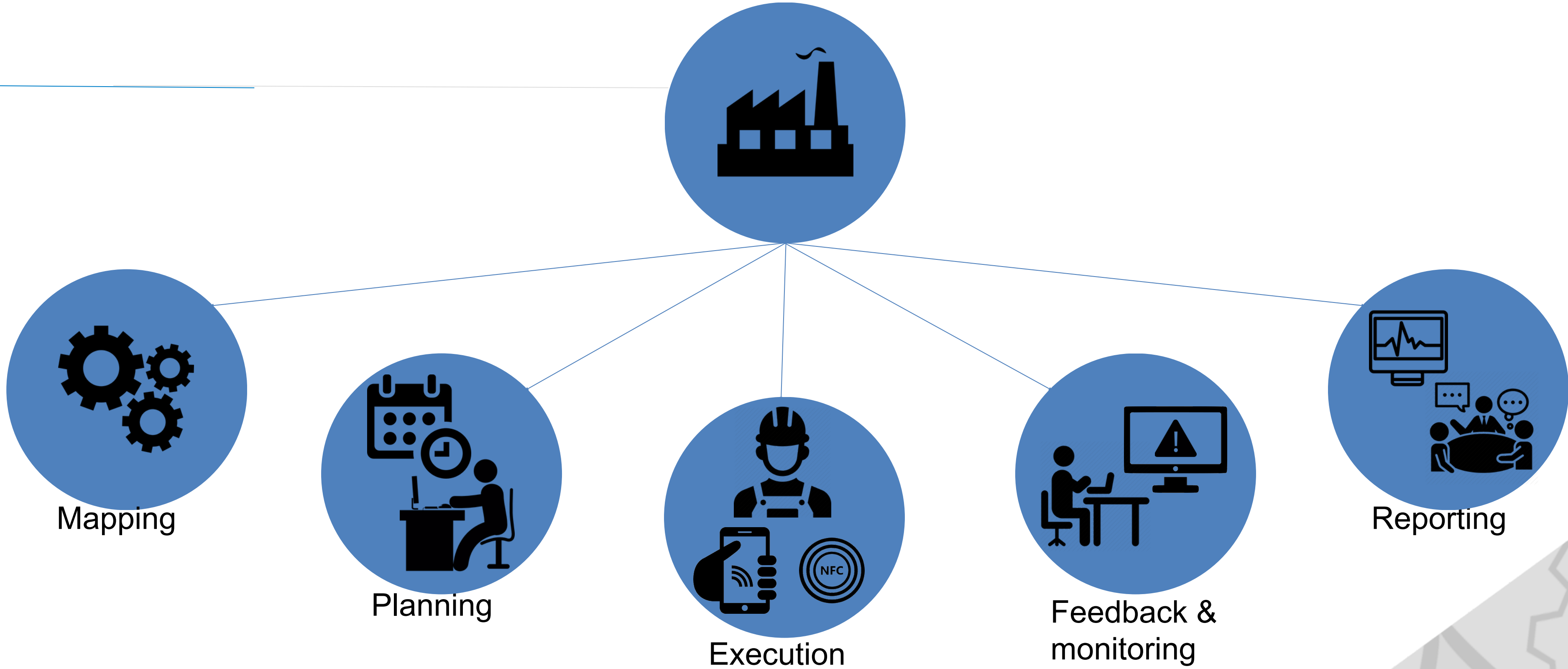

Mapping

Planning

Execution

Feedback & monitoring

Reporting

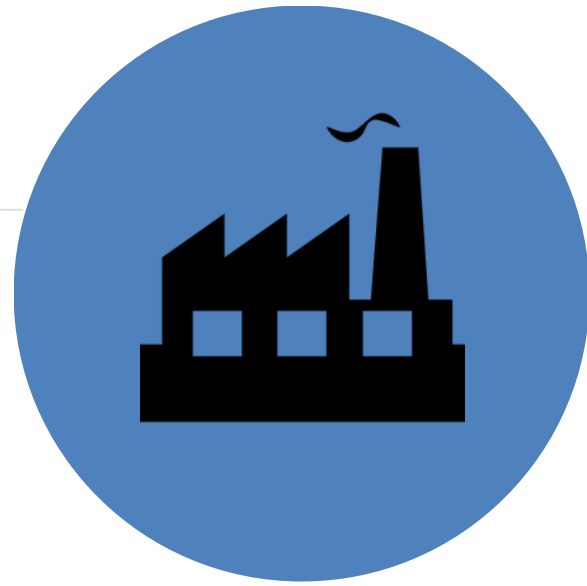

Task Management



Multiple Site



Independent Platform



Productivity Increase

THANK YOU FOR YOUR ATTENTION